



**SPORT TRANSFER**  
sports equipment

SPORT-TRANSFER sp. z o.o.  
Jawornik 564  
32-400 Myślenice  
Tel. +48 12 649 14 83  
e-mail: biuro@sport-transfer.com.pl

## INSTRUCTIONS FOR ASSEMBLY AND USE OF SPORTS EQUIPMENT

Product: **Standard aluminium volleyball posts with sleeves**  
Code: 11 002, 11 015

The volleyball posts meets requirements of the PN-EN 1271 standard: "Playing Field Equipment– Volleyball Equipment. Functional And Safety Requirements, Test Methods".

### 1. Components

Number	Part/subassembly name	Quantity per product
1	Square steel posts	2
2	Slat with the screw tensioner	1
3	Slat with net hooks	1
4	Eccentric locking device	2
5	Crank	1
6	Square steel sleeve	2
7	Cover of the sleeves	2

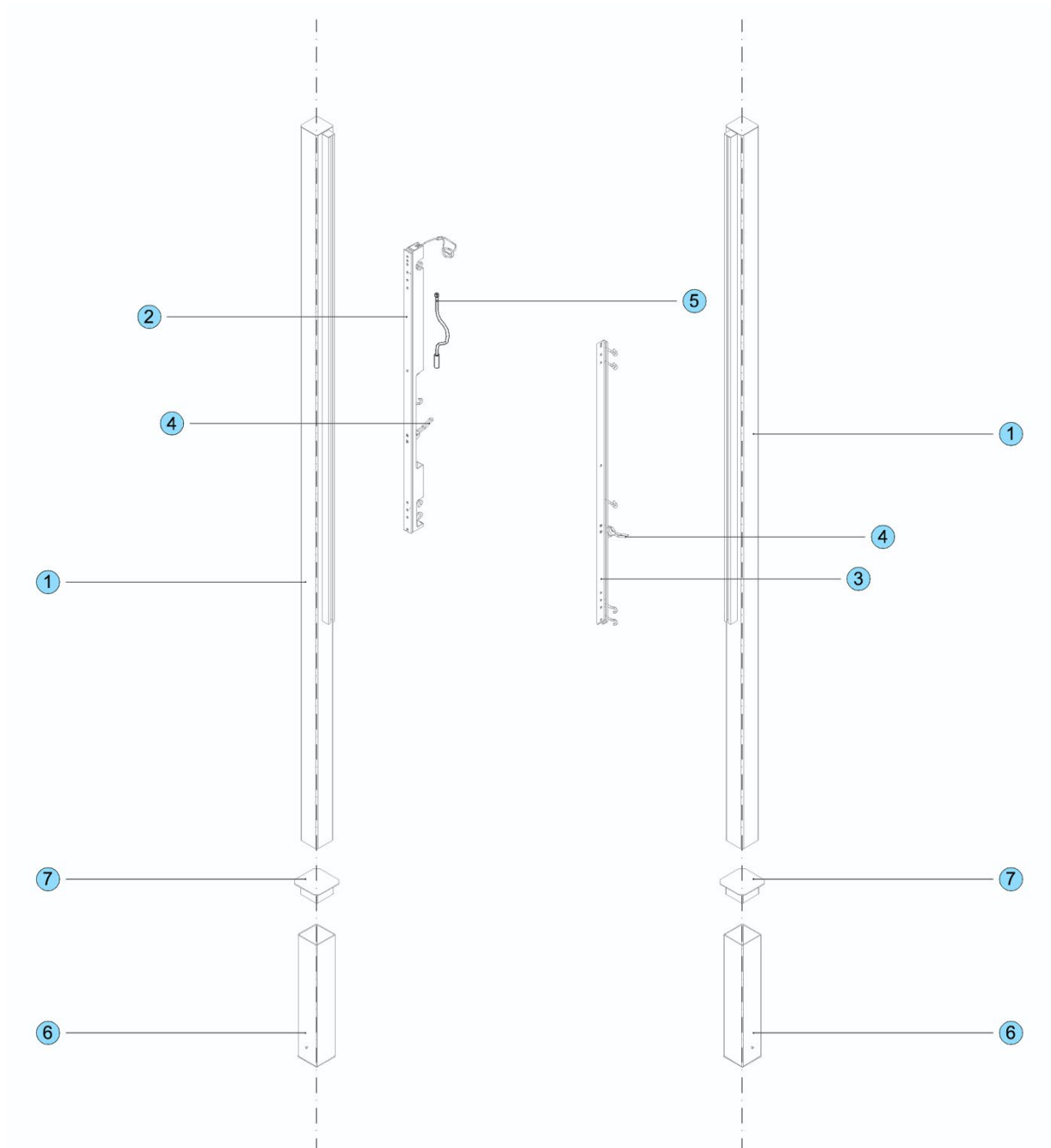

## 2. Installing the volleyball post

- Place the sleeves in the prepared holes in the ground at an angle of  $\sim 2^\circ$  of the inclination to the vertical in the direction outside to the playing field, with an axial distance of 11 m (axial distance from 10 to 11 m is allowed).
- For the sleeves mounted on the outdoor pitch, the upper edge of the cover frame shall coincide with the playing field level, in the halls the upper edge of the sleeve is to be 30 mm below the floor level.
- Recommended foundation size is min. 350x350 mm and depth min. 800 mm on the outdoor playing fields and min. depth 500 mm in sports halls with concrete class C20/25.

- The final size of the foundation and the class of concrete used should depend on the strength condition: the horizontal force  $P=2000N$  applied to the post placed in the sleeve at the height of 2430 mm should not cause loosening of the sleeve fixing or the whole foundation and the ground frost zone in the given area.
- The posts in the sleeve can be installed and operated after the concrete has completely dried out (min. 7 days).

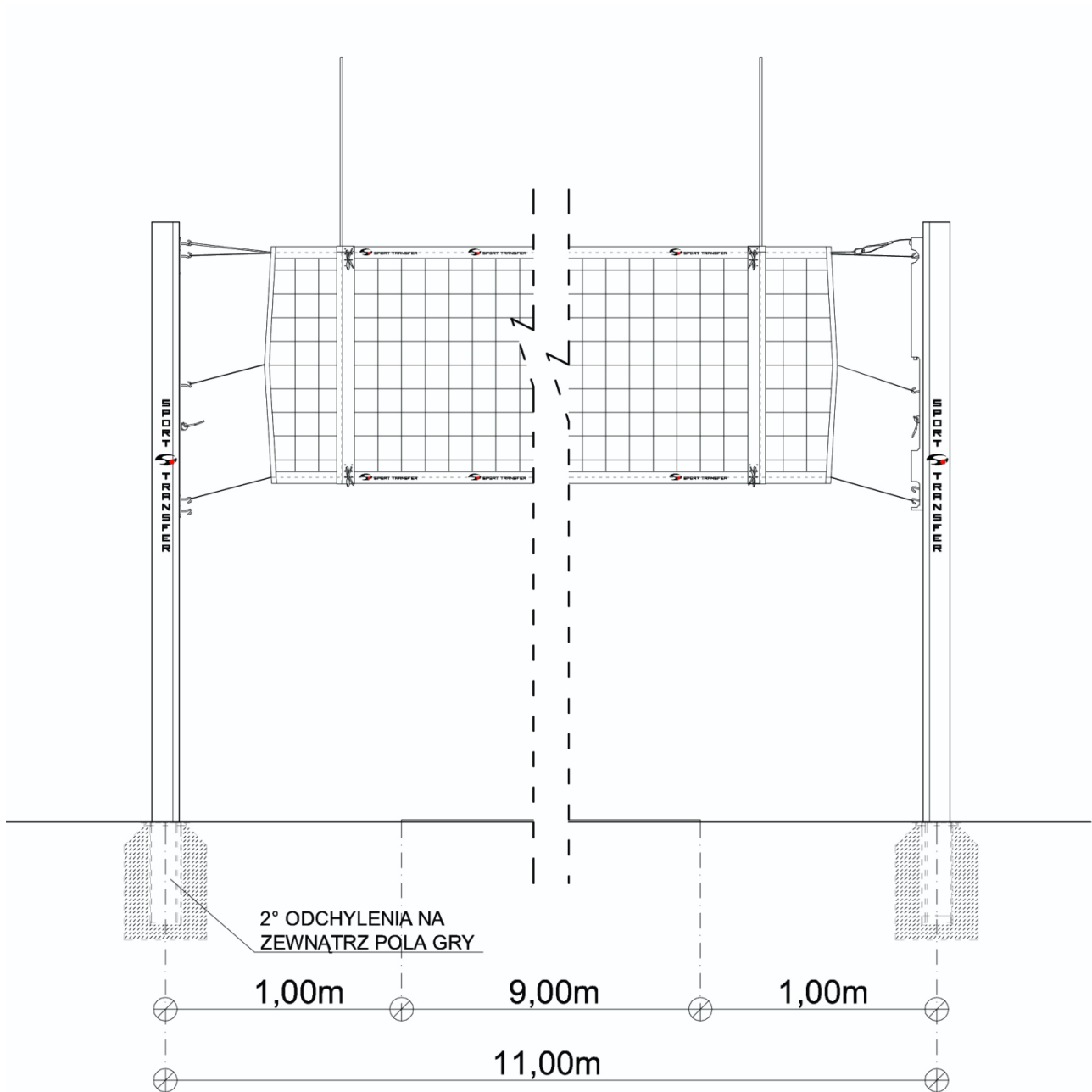

### 3. Net fastening

- The net carrying line is fixed on the top hook (8) of the batten in the hook rail.
- The other end of the suspension strand is hooked onto the snap hook located at the slat with the screw tensioner (2).
- By turning the crank (5) applied to the joint in the middle of the slat with the tensioner, tighten the net's suspension strand. In a correctly tensioned grid, the height of its top edge, measured at the centre, must not be less than 1 cm in relation to the height measured above the sidelines of the playground.
- After tensioning the suspension strand, the net is tensioned using tensioning strings and tied to the hooks (10) on the slats of both rails so that the net is symmetrical in relation to the transverse axis of the playing field.

Suspension height of the net in metres: 2.43 for men; 2.24 for women; 2.35 for juniors "m"; 2.20 for juniors "k"; 1.55 – badminton.

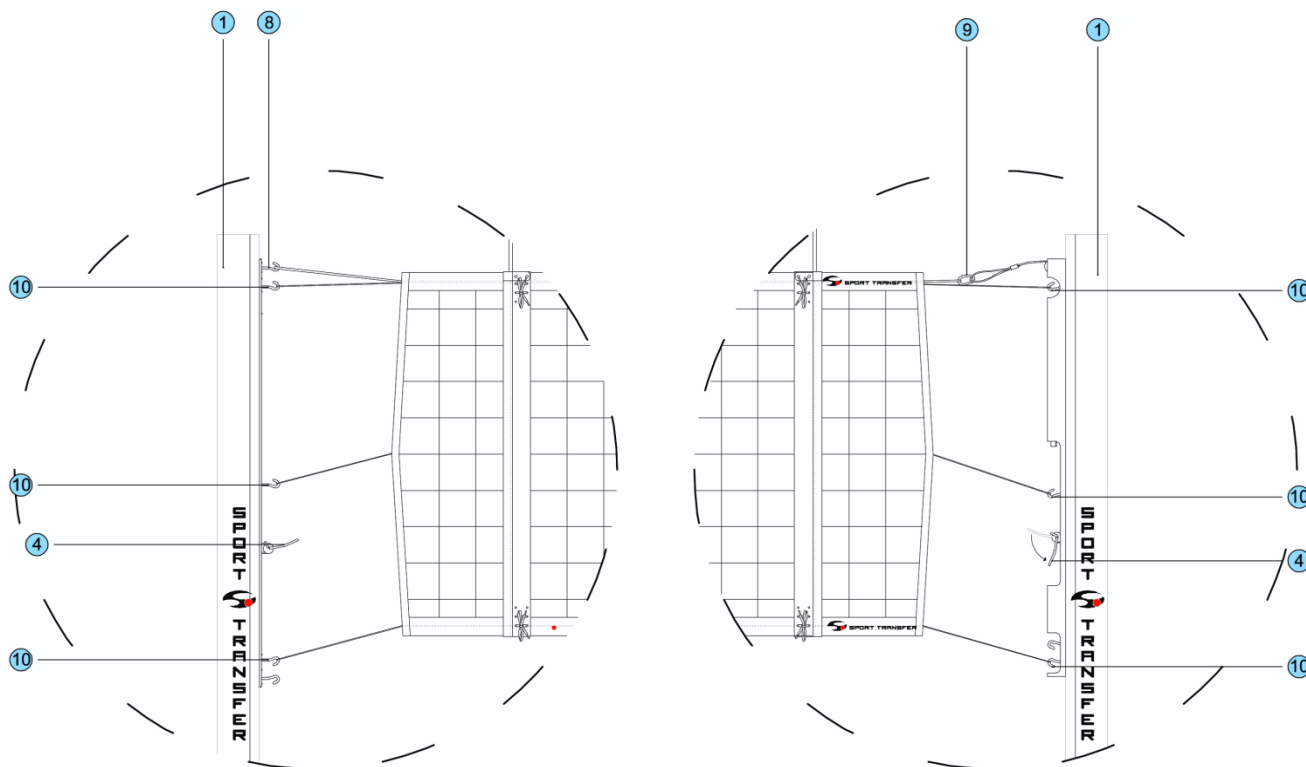

### 4. Using the posts

- a) Steel volleyball posts are designed for playing volleyball and badminton, especially in open-air facilities.
- b) The posts in the sleeves (6) are set so that the elements used to suspend the grid are directed to the playing field.

c) The posts are stepless adjustable in height. In order to set the desired height, unlock the eccentric (4) by turning the handle upwards and moving the tensioning slat (2) / hook slap (3) to the desired height. Then, pressing the eccentric handle (4) downwards, lock the slats at the desired height.

**Note: adjust the height of the net suspension without tensioning the net**

d) After adjusting the height, tension the net according to the instructions.

e) Each time after the game is over, loosen the tension on the net suspension strand.

**ATTENTION: Do not climb or hang on any part of the posts or nets or unlock the eccentric during the game or when the net is tensioned.**

For additional safety, use pole shields Art. No. 11 104.